

SureShot Lubrication System Installation Guide



Installation

Thank you for purchasing a SureShot kit for your equipment. This instruction guide will walk you through the basic steps to install the kit yourself, with only common tools needed. Please follow these instructions carefully.

Tools needed

- Drill with 1/4" bit to drill through equipment frame
- Pliers to remove zerk fittings from equipment
- Wrenches: 7/16", 11mm, 1/2", and 14mm
- Utility knife
- Sharp cutting pliers or scissors

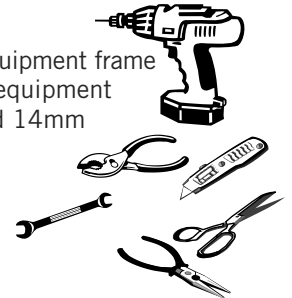

Included with the SureShot kit

Quantity		4C	6C	8C	10C	12C	SSPR		4C	6C	8C	10C	12C	SSPR	
Lubrication divider block		1	1	1	1	1	0	Elbow adapter 1/8 NPT		2	3	4	4	6	1
Crossport bar		1	1	1	1	1	1	Pre-filled nylon tubing 1/4" OD x 0.062 Wall		25'	50'	75'	75'	100'	25'
Straight adapter 1/8 NPT x 1/4-28		2	2	4	4	4	1	Tubing insert		8	12	16	20	24	2
Elbow adapter 1/8 NPT F x 1/4-28		2	3	4	4	6	1	Plastic zerk cover		1	1	1	1	1	1
45 degree adapter 1/8 NPT x 1/8 NPT		2	2	4	4	4	1	Heavy-duty cable tie		8	12	16	20	24	2
65 Degree angle zerk fitting 1/4 NPT		1	1	1	1	1	1	Screw socket head 1/4-20 x 1.25 L		2	2	2	2	2	0
Connector assembly 1/4" TBG x 1/8 BSPT		4	6	8	10	12	2	Nut 1/4-20		2	2	2	2	2	0
Connector assembly 1/4" TBG x 1/8 NPT		4	6	8	10	12	2	Spacer washer		2	2	2	2	2	0

Before installation, lay all parts out on ground and inspect.



WARNING Test each point that will be used in the lubrication system by manually pumping grease (grease gun) to each zerk fitting to confirm the point with accept grease.

STEP 1

ATTACH BLOCK TO FRAME

Locate a central location on the equipment frame to mount the lubrication block. Use the enclosed drill template to mark the drill marks (See page 4). Use a 1/4" drill bit to make the hole.

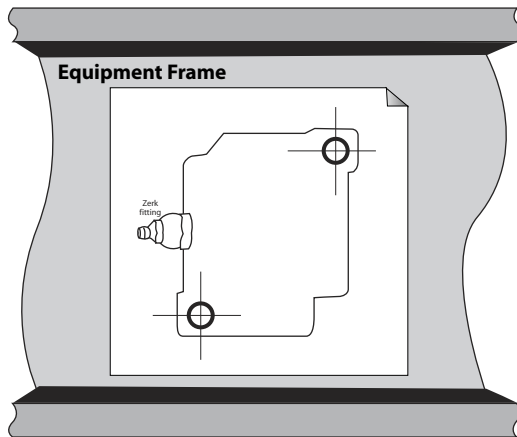

Use the spacer washer, nut and screw socket head as shown to attach the block to the frame.

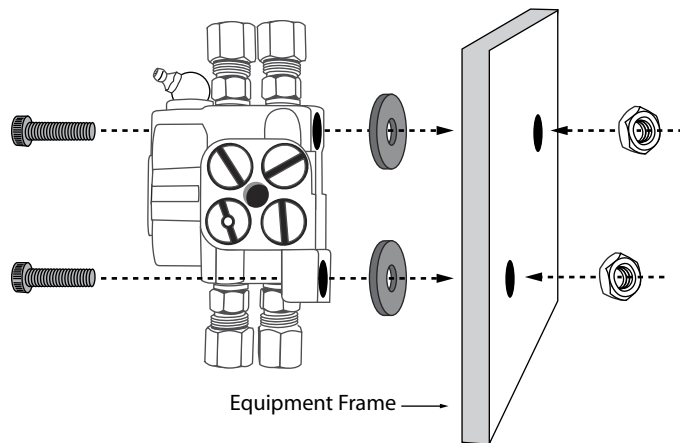

STEP 2

REMOVE EXISTING ZERK FITTINGS

Use appropriate tools to remove the zerk fittings from all the points you wish to lubricate on your equipment.

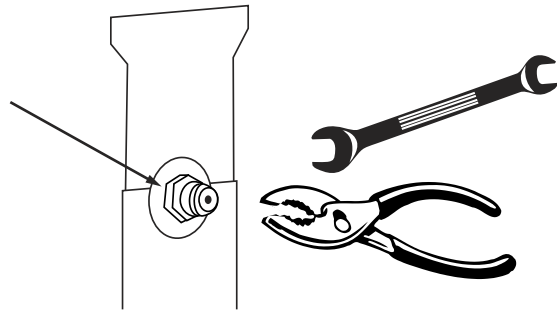

If your equipment has push in zerk fittings, you can order the ChassisCare push zerk lock fitting (part number 35160).

STEP 3

INSERT ADAPTERS

Your SureShot kit comes with a wide array of lubrication adapters. Choose the adapters that fit the best with your spacing at the lubrication point.

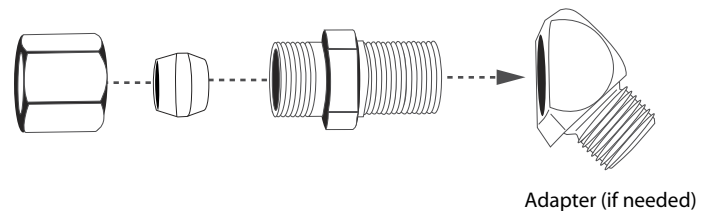

STEP 4

ATTACH PRE-FILLED TUBING AT THE LUBRICATION POINTS

It is very important that you route the lubrication lines from the bearing points back to the block. Always start with the longest distance and work towards the shortest. This will ensure you have sufficient tubing to complete installation.

WARNING Do not tighten down fittings until all tubing is run at the correct lengths.

Insert the tube insert into one end of the tubing, slide compression nut on tubing then slide compression sleeve on, and finally insert into the adapter furthest from the lubrication divider block. Use a 14mm wrench to tighten. **NOTE: These compression fittings will clamp down on the tubing, providing a secure connection.** In the event you need to remove the tubing during the installation process, just loosen the adapter, remove the tubing insert and trim the end of the tubing before repeating the installation step.

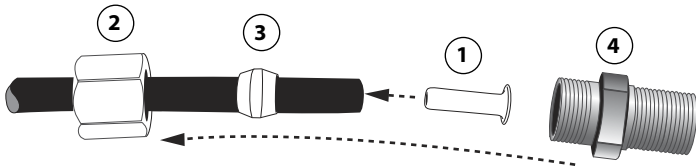

STEP 5

ATTACH THE TUBING TO DIVIDER BLOCK

Once you have routed the lubrication tubing back to the divider block, trim to fit. Insert tubing insert into the divider block end of the tubing and insert into one of the outlets on the block. Tighten with wrench.

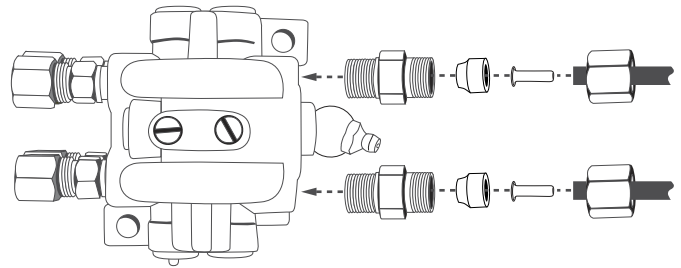

REPEAT STEPS 4-6 FOR EACH ATTACHED LUBRICATION POINT

When system is installed, just attach a manual grease gun to the divider block and push grease into the divider block. Watch the indicator pin to verify movement of grease inside the block. When a collar of fresh grease appears at the bearing being lubricated, you know there is sufficient grease at that point.

Crossport installation

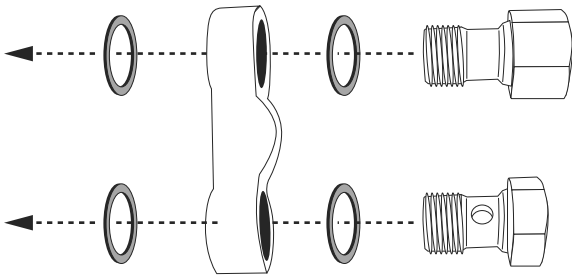

Crossport Assembled

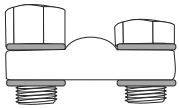

Crossport Attached to Block

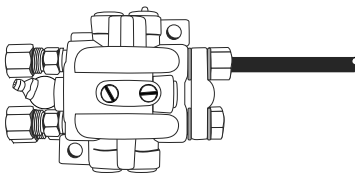

DRILL TEMPLATE

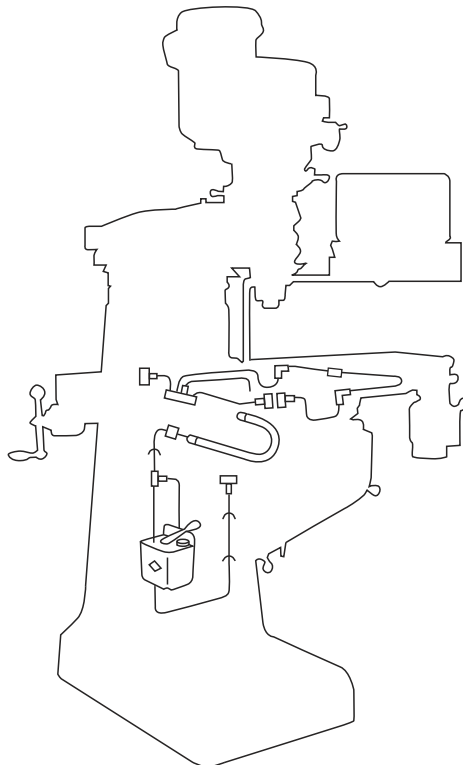
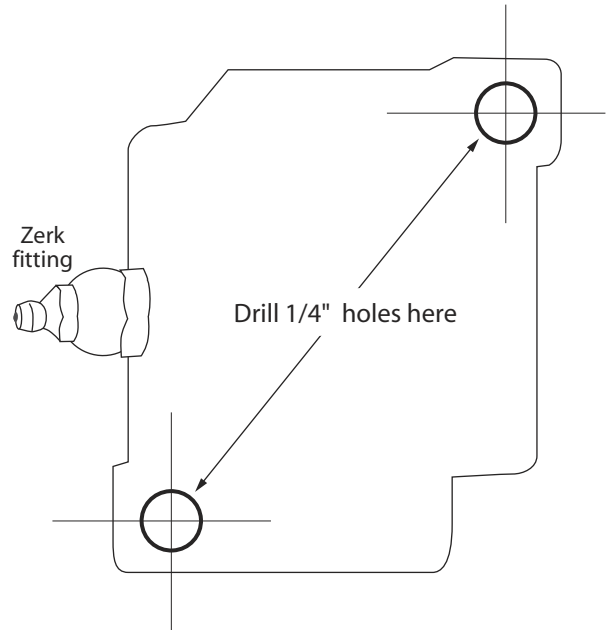

Common lubrication points

